

SMART Program Specific Metering Wiring Diagrams

January 2019

Eversource Metering Wiring Information & Diagrams

SMART Program Specifics

- For more information on the **SMART Program** please visit www.masmartsolar.com

Agenda

- Eversource Interconnection Changes for the **SMART Program**
- Meter Configurations
- Meter Configuration Diagrams

Metering – Technical Question Contacts:

- Contact via email: DGMeteringQs@Eversource.com
 - Eastern MA – Paul E. Murphy
 - Western MA - Gregory M. Pivin

Remaining the Same

- Requests for meters are made to the DG Interconnections team
- Eversource will install and support all Revenue and Production meters
- Eversource will provide a PTO upon successful connection

Changes for the SMART Program

- DG will ask for your SMART Application ID upfront
 - This requires the submittal of the SMART Application via the Web Portal prior to contacting the DG Interconnections team
- For Behind the Meter Installations (BTM)
 - Customer will be charged the cost of BTM Production Meter and installation fees upon submission of the SMART Application Fee via the Web Portal
 - Note: for larger, complex systems (additional charges still apply from ES engineering, i.e., CTs', PT's, etc.)
 - Will require customer-installed wiring, and installation of a second meter socket
 - Must be adequately accessible, proximate to existing utility revenue meter

Meter Configurations

Service Type		Project size	Meter Type
120/240V Single Phase	3 - wire	Under 60KW	Form 2S Bridge
120/208V Single Phase	3 - wire	Under 60KW	Form 12S Bridge
120/208V Three Phase	4-wire	Under 60KW	Form 16S Bridge
277/480V Three Phase	4-wire	Under 60KW	Form 16S Bridge
120/240V Single Phase	3 - wire	Over 60KW	Form 2S Interval
120/208V Single Phase	3 - wire	Over 60KW	Form 12S Interval
120/208V Three Phase	4-wire	Over 60 KW	Form 16S Interval
277/480V Three Phase	4-wire	Over 60KW	Form 16S Interval
IT Rated Single Phase (secondary CTs)		Over 320A	Form 4S Interval
IT Rated Three Phase (secondary CTs/PTs)		Over 320A	Form 9S Interval
IT Rated Single Phase (primary CTs)		Over 320A	Form 4S Interval
IT Rated Three Phase (primary CTs/PTs)		Over 320A	Form 9S Interval

General Meter Installation Guidelines

1. It is the responsibility of the Interconnecting Customer/Contractor (IC) to adhere to all applicable codes, standards and requirements including Eversource meter installation requirements as described in the Information and Requirements (I&R) publication, Eversource's Interconnection Tariff, the National Electrical Code (NEC), State and Municipal building requirements.
2. See the appropriate I&R publication for either EMa or WMa for the IC responsibilities for procuring and installing the appropriate meter socket and any associated instrument transformer (IT) enclosure (if required).
3. Eversource will install the meter for all services. If required, Eversource will also provide all instrument transformers for any new IT-rated installation and make all secondary wiring connections to the meter.
4. Any primary metering, if required, will be coordinated with Eversource.
5. Each meter socket shall be marked with the unique identification such as a "SOLAR PRODUCTION" site for the location serviced prior to the start of any service work to ensure proper meter installation. If there are more than one meter, mark the appropriate SPA Key on the meter socket to identify one service from the other.
6. The wiring diagrams within this document represent standard conceptual designs for commonly used service installations. Wiring configurations outside the norms shown within this document will require additional time for Eversource review and approval.
7. The IC is responsible for obtaining all approvals from the Authority Having Jurisdiction as soon as the work is completed.
8. Where the existing PCC meter is inside, the IC will upgrade their service connection to change it to an outside location.
9. All metering maintained by Eversource will be required to be accessible to Utility personnel at all times.
10. All self-contained meter sockets will be wired such as the top (line) side is toward the Utility feed and the bottom (Load) side is toward the solar generation and/or battery storage.
11. For any IT-rated services, all transformer polarity marks will be wired pointing toward the Utility feed.
12. Eversource reserves the right to amend this document from time to time as necessary.

Metering Diagrams

Metering Notes:

- **BTM:** Behind the Meter installation option
- **DER:** Distributed Energy Resource
- **DG:** Distributed Generator/Solar Array
- **ESS:** Energy Storage System
- **EPS:** Electric Power System
- **IC:** Interconnecting Customer
- **PCC:** Point of Common Coupling
- **PoC:** Point of Connection
- **PTO:** Permission to Operate
- **SPAKey:** Smart Program Account number

1a. BTM <60kW

Retail

Residential/Commercial DG Customer
Behind the Meter Ma SMART <60 kW
With No ESS System
UTILITY – AREA EPS

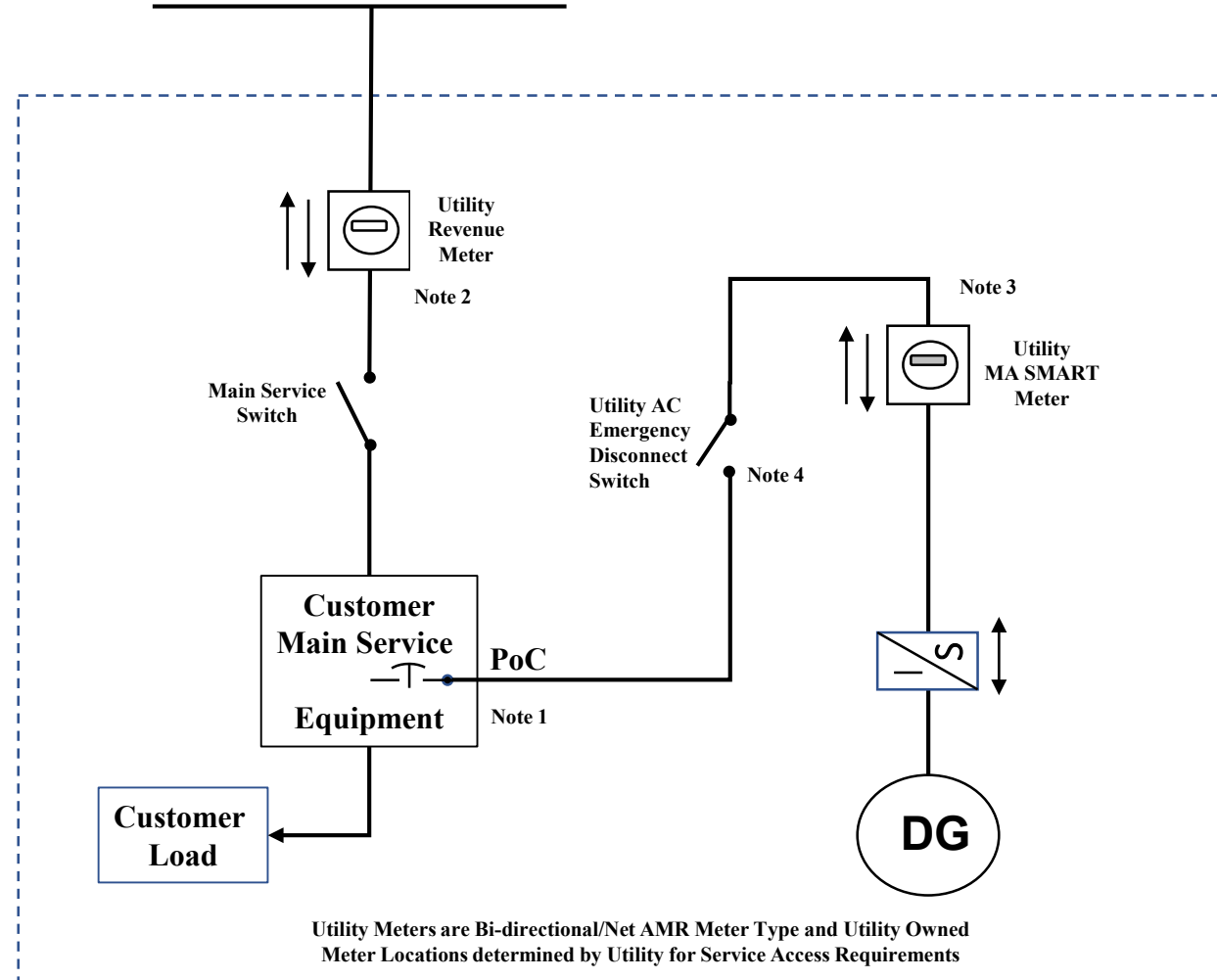

This diagram is representative of a standard design. Please contact Eversource for approval, if a different configuration is needed.

- Note 1**
* All interconnection points are required to be placed behind the utility meter
For behind the meter installations all interconnect points required to be located behind the utility revenue meter.
>>> No connections are to be made within the revenue meter socket or in utility transformer compartment. <<<
- Note 2**
* Utility meters located inside customers facility, the interconnecting customer will be required to upgrade and have the meter relocated outside the customers facility near both the production meter and the utility disconnect switch.
- Note 3**
* Utility feed for the MA SMART meter, the socket is required to be wired top side utility, bottom side inverter.
* The utility AC emergency disconnect switch is required to be located on the ground level within vicinity of the utility revenue meter where our utility personal will have 24 / 7 access to it.
- Note 4**
* The utility AC emergency disconnect switch is required to be located ahead of the SMART where utility personal will be able to isolate the metering circuit.
- Special Notes:**
* All meters and switches are required to be grouped unless interconnection contractor request and is granted a written variance.

1b. BTM <60kW

Retail

Residential/Commercial DG Customer
Behind the Meter Ma SMART <60 kW
With AC coupled ESS System
UTILITY – AREA EPS

This diagram is representative of a standard design. Please contact Eversource for approval, if a different configuration is needed.

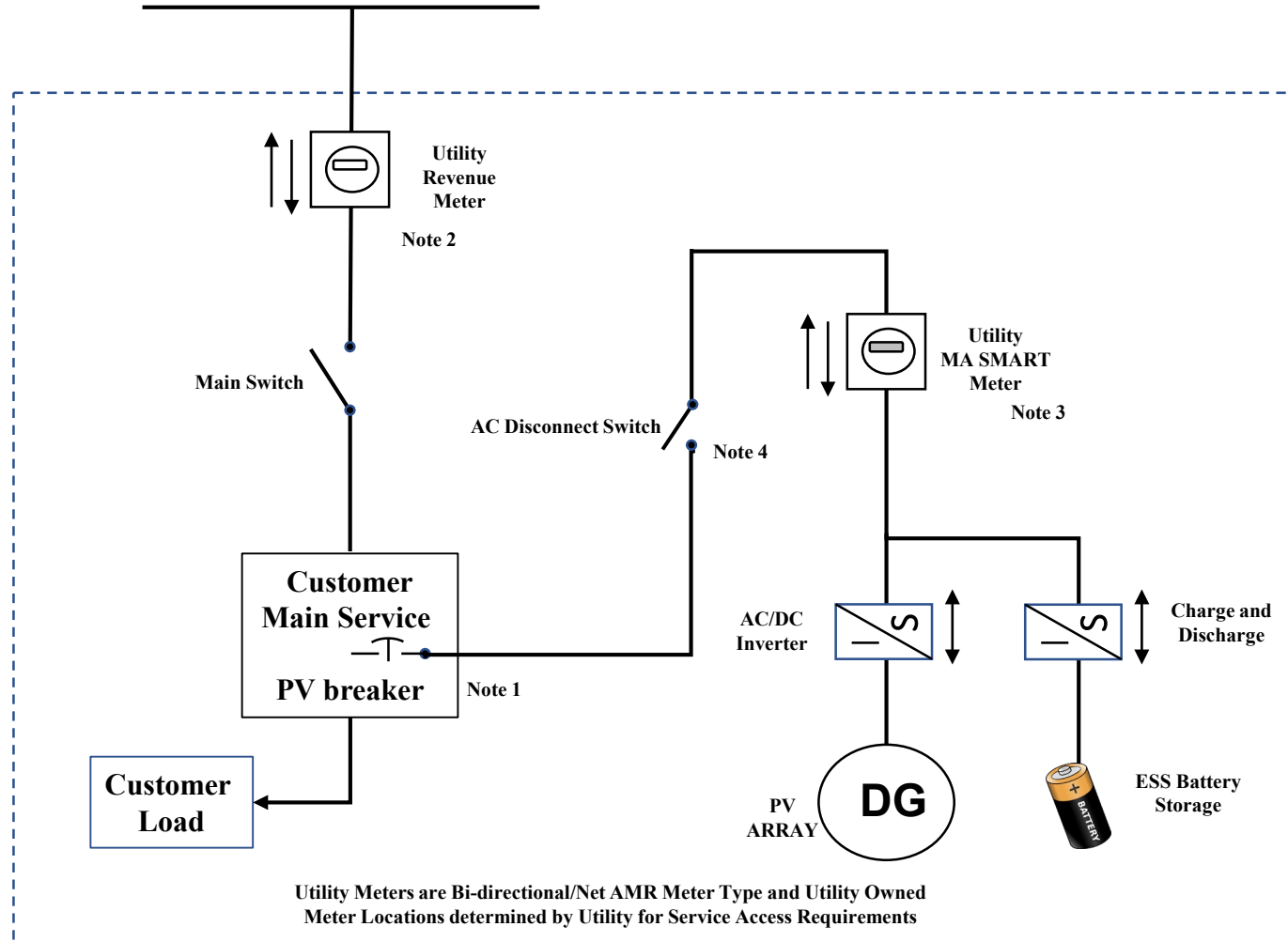

Note 1

* All interconnection points are required to be placed behind the utility meter
For behind the meter installations all interconnect points required to be located behind the utility revenue meter.
>>> No connections are to be made within the revenue meter socket or in utility transformer compartment. <<<<

Note 2

* Utility meters located inside customers facility, the interconnecting customer will be required to upgrade and have the meter relocated outside the customers facility near both the production meter and the utility disconnect switch.

Note 3

* Utility feed for the MA SMART meter, the socket is required to be wired top side utility, bottom side inverter.
* The utility AC emergency disconnect switch is required to be located on the ground level within vicinity of the utility revenue meter where our utility personal will have 24 / 7 access to it.

Note 4

* The utility AC emergency disconnect switch is required to be located ahead of the SMART where utility personal will be able to isolate the metering circuit.

Special Notes:

* All meters and switches are required to be grouped unless interconnection contractor request and is granted a written variance.

1c. BTM <60kW

Retail

Residential/Commercial DG Customer
Behind the Meter Ma SMART <60 kW
With DC coupled ESS System
UTILITY – AREA EPS

This diagram is representative of a standard design. Please contact Eversource for approval, if a different configuration is needed.

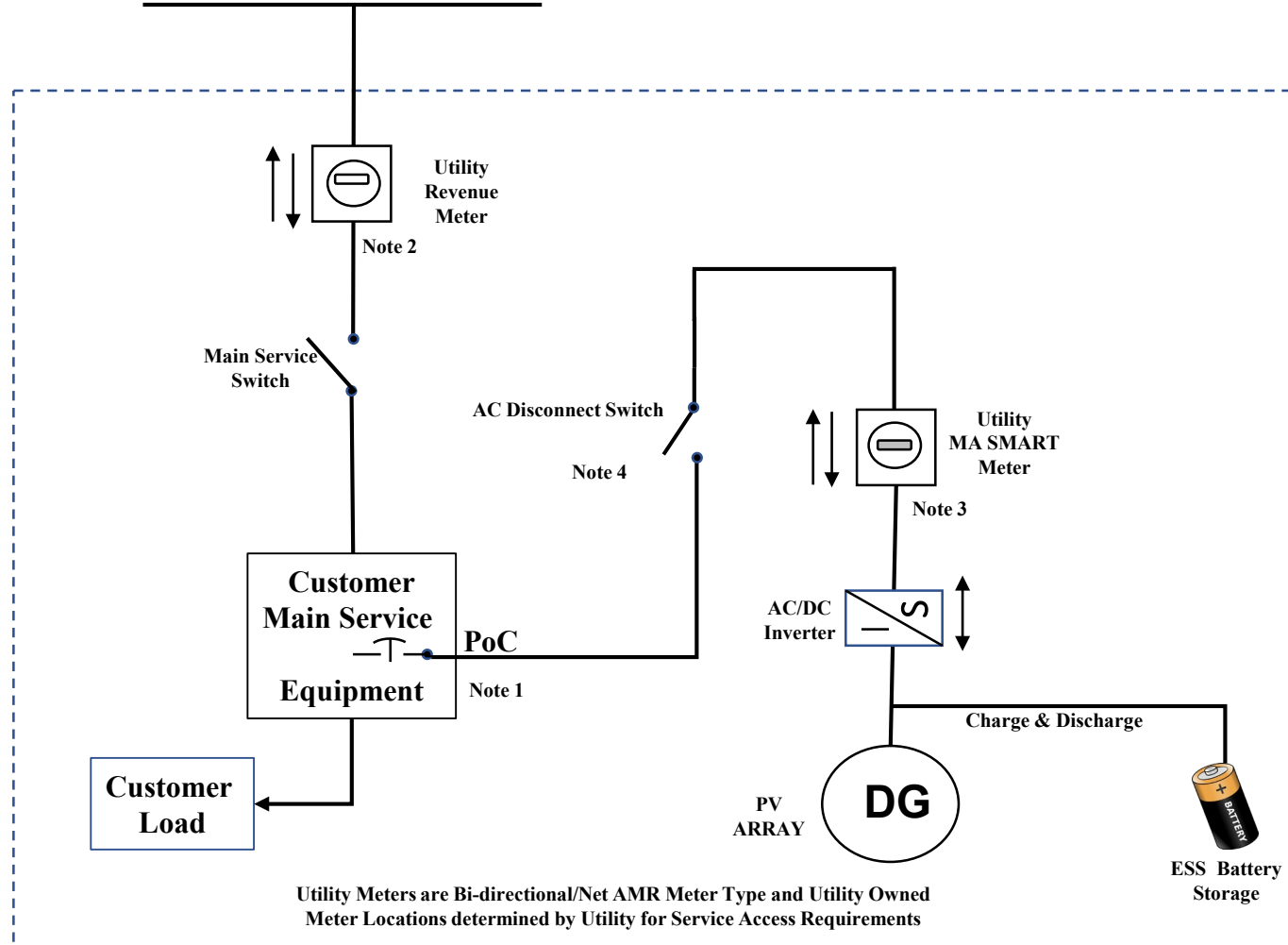

- Note 1**
* All interconnection points are required to be placed behind the utility meter
* For behind the meter installations all interconnect points required to be located behind the utility revenue meter.
>>> No connections are to be made within the revenue meter socket or in utility transformer compartment. <<<
- Note 2**
* Utility meters located inside customers facility, the interconnecting customer will be required to upgrade and have the meter relocated outside the customers facility near both the production meter and the utility disconnect switch.
- Note 3**
* Utility feed for the MA SMART meter, the socket is required to be wired top side utility, bottom side inverter.
* The utility AC emergency disconnect switch is required to be located on the ground level within vicinity of the utility revenue meter where our utility personal will have 24 / 7 access to it.
- Note 4**
* The utility AC emergency disconnect switch is required to be located ahead of the SMART where utility personal will be able to isolate the metering circuit.
- Special Notes:**
* All meters and switches are required to be grouped unless interconnection contractor request and is granted a written variance.

Utility Meters are Bi-directional/Net AMR Meter Type and Utility Owned
Meter Locations determined by Utility for Service Access Requirements

2a. BTM >60kW to 500kW

AC Connection to Utility EPS 60kW – 500kW
 Behind the Meter Ma SMART
 Without ESS System
 Utility Service Connection
 3-Phase 4-Wire System
 Secondary Metering

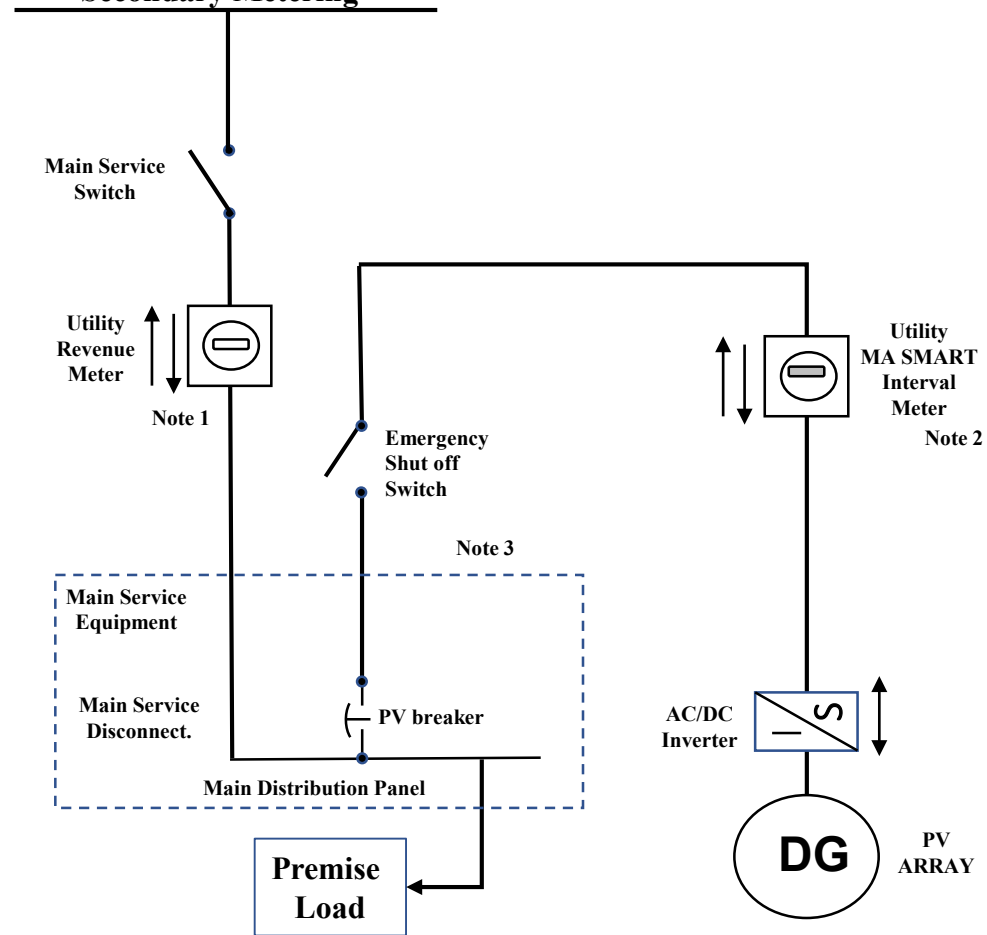

This diagram is representative of a standard design. Please contact Eversource for approval, if a different configuration is needed.

Note 1

* Utility Revenue Meter installed will be Bi-directional/NET/Recording meter and meet the requirements of both tariff and billing rate.

* Where Utility Meter is located inside, the interconnecting customer will upgrade the existing service and move the metering location outside with the Utility Ma SMART meter.

Note 2

* Must have a Cellular connection at Meter location.
 * Meter will have bi-directional interval recording capabilities.
 * Secondary metering CTs/VTs may be required.

Note 3

* The Emergency shut off switch shall be within vicinity of the utility meter and accessible to Utility personnel.

Note 4

* Production meter current transformers polarity markings required to be pointed towards utility.

Special Notes:

* All meters and switches are required to be grouped unless interconnection contractor request and is granted a written variance.

2b. BTM >60kW to 500kW

AC Connection to Utility EPS 60kW – 500kW
 Behind the Meter Ma SMART
 With AC coupled ESS System
 Utility Service Connection
 3-Phase 4-Wire System
 Secondary Metering

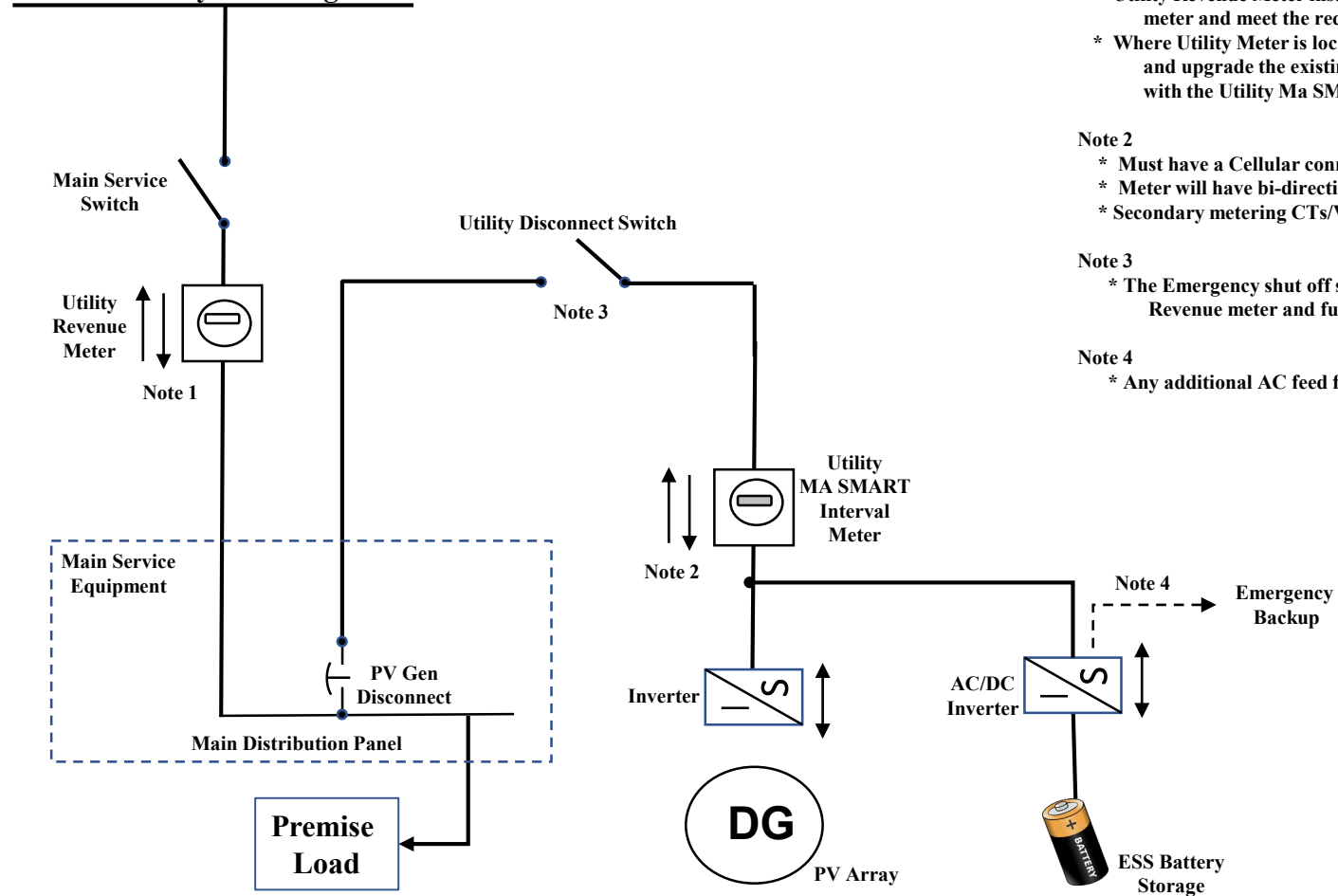

This diagram is representative of a standard design. Please contact Eversource for approval, if a different configuration is needed.

- Note 1
- * Utility Revenue Meter installed will be Bi-directional/NET/Recording meter and meet the requirements of both tariff and billing rate.
 - * Where Utility Meter is located inside, the interconnecting customer will and upgrade the existing service to move the metering location outside with the Utility Ma SMART meter.
- Note 2
- * Must have a Cellular connection at Meter location.
 - * Meter will have bi-directional interval recording capabilities.
 - * Secondary metering CTs/VTs may be required.
- Note 3
- * The Emergency shut off switch shall be located within the vicinity of the Revenue meter and fully accessible to Utility personnel.
- Note 4
- * Any additional AC feed from the inverter will be un-metered

2c. BTM >60kW to 500kW

AC Connection to Utility EPS 60kW – 500kW
 Behind the Meter Ma SMART
 With DC coupled ESS System
 Utility Service Connection
 3-Phase 4-Wire System
 Secondary Metering

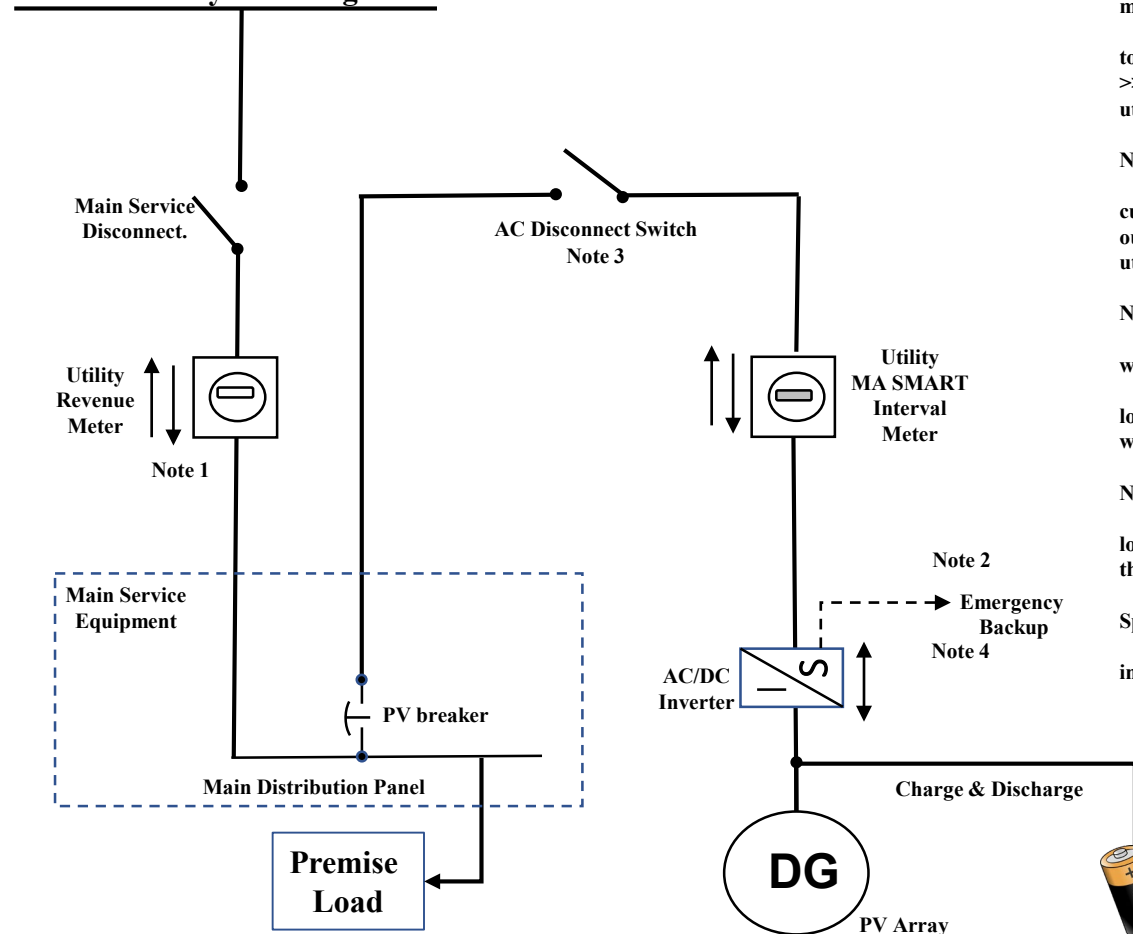

This diagram is representative of a standard design. Please contact Eversource for approval, if a different configuration is needed.

Note 1
 * All interconnection point is required to be placed behind the utility meter
 * For behind the meter installations all interconnect points required to be located behind the utility revenue meter.
 >>> No connections are to be made within the revenue meter socket or in utility transformer compartment. <<<

Note 2
 * Utility meters located inside customers facility, the interconnecting customer will be required to upgrade and have the meter relocated outside the customers facility near both the production meter and the utility disconnect switch.

Note 3
 * Utility feed for the MA SMART meter, the socket is required to be wired top side utility, bottom side inverter.
 * The utility AC emergency disconnect switch is required to be located on the ground level within vicinity of the utility revenue meter where our utility personal will have 24 / 7 accessible.

Note 4
 * The utility AC emergency disconnect switch is required to be located ahead of the SMART where utility personal will be able to isolate the metering circuit.

Special Notes:
 * All meters and switches are required to be grouped unless interconnection contractor request and is granted a written variance.

3a. BTM >500kW

AC Connection to Utility EPS 500kW and Greater
 Behind the Meter Ma SMART
 With No ESS System
 Utility Service Connection
 3-Phase 4-Wire System
 Primary Metering

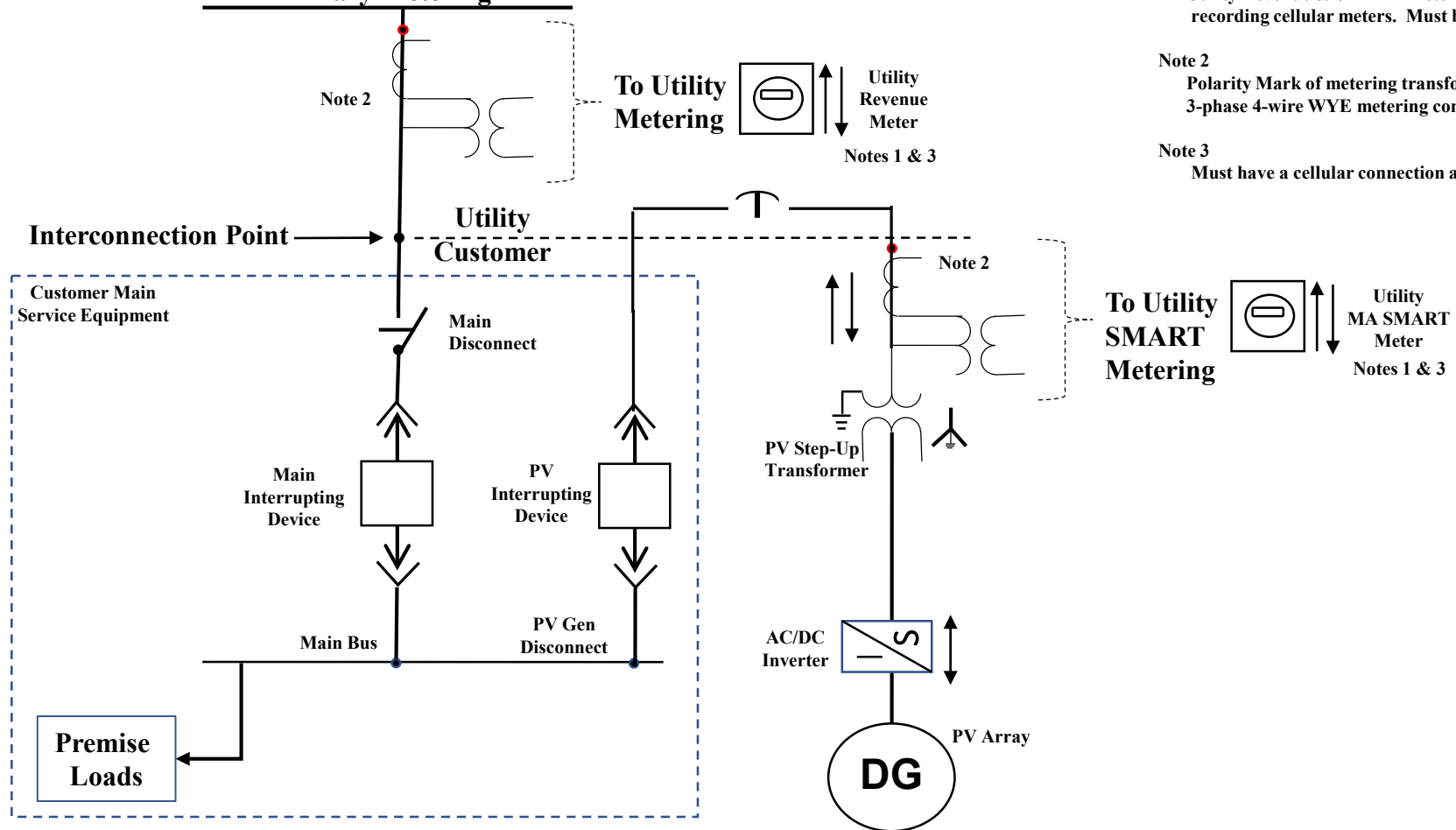

This diagram is representative of a standard design. Please contact Eversource for approval, if a different configuration is needed.

- Note 1
Utility Revenue & SMART Meters installed will be Bi-directional recording cellular meters. Must be accessible.
- Note 2
Polarity Mark of metering transformers is to be toward the Utility feed. 3-phase 4-wire WYE metering connection.
- Note 3
Must have a cellular connection at the meter location.

3b. BTM >500kW

AC Connection to Utility EPS 500kW and Greater
 Behind the Meter Ma SMART
 With AC coupled ESS System
 UTILITY SERVICE Connection
 3-Phase 4-Wire System
 Primary Metering

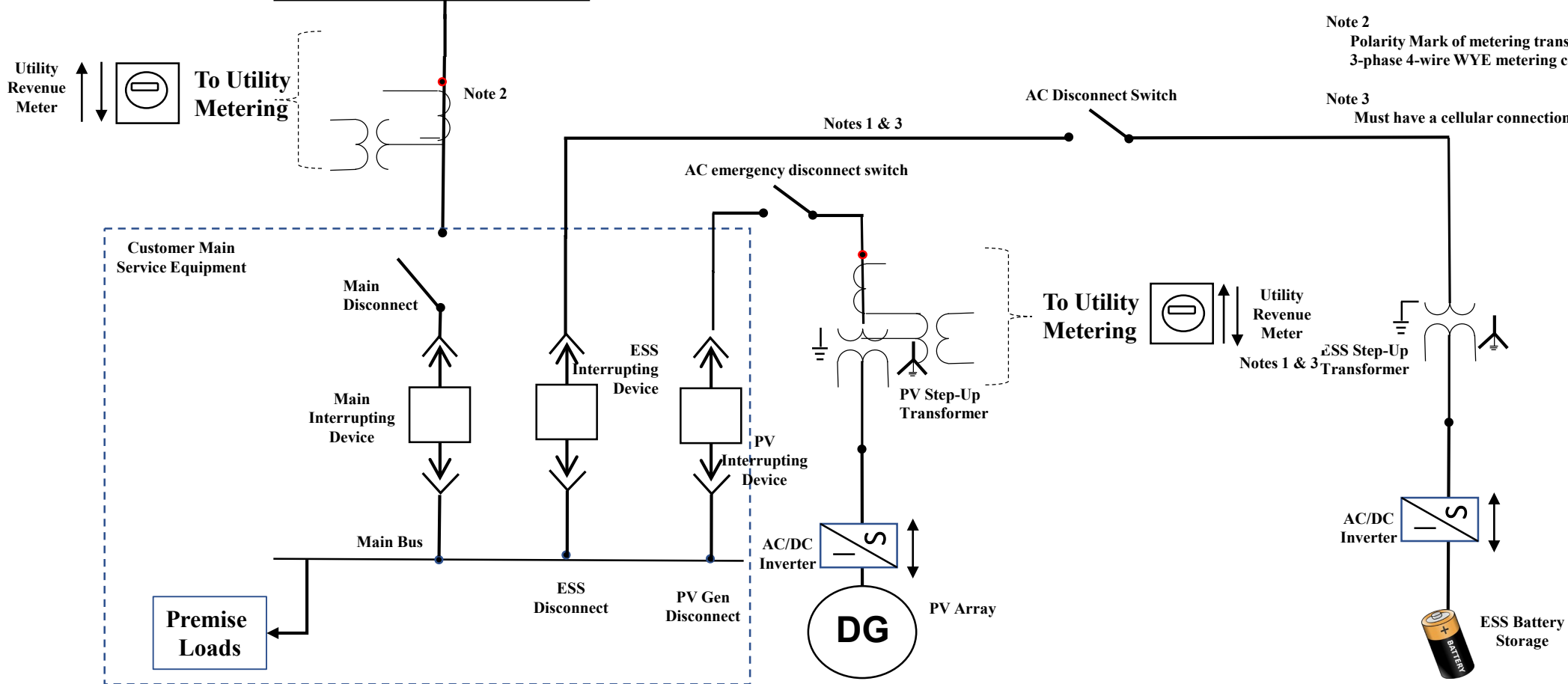

This diagram is representative of a standard design. Please contact Eversource for approval, if a different configuration is needed.

3c. BTM >500kW

AC Connection to Utility EPS 500kW and Greater
 Behind the Meter Ma SMART
 With DC coupled ESS System
 UTILITY SERVICE Connection
 3-Phase 4-Wire System
 Primary Metering

This diagram is representative of a standard design. Please contact Eversource for approval, if a different configuration is needed.

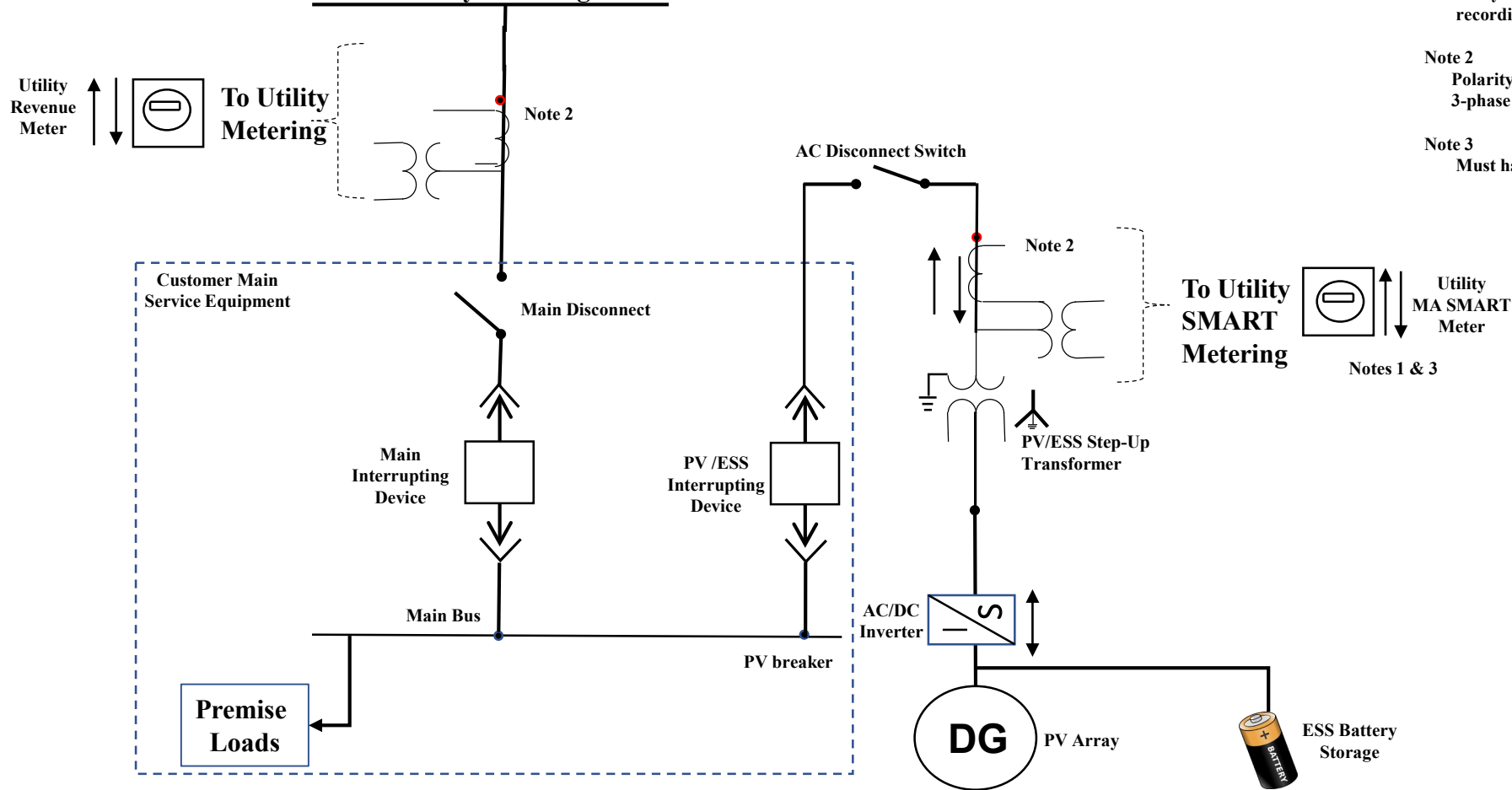

- Note 1
Utility Revenue & SMART Meters installed will be Bi-directional recording cellular meters. Must be accessible.
- Note 2
Polarity Mark of metering transformers is to be toward the Utility feed. 3-phase 4-wire WYE metering connection.
- Note 3
Must have a cellular connection at the meter location.

Stand-Alone Wiring Diagrams

4a. Stand Alone <60kW

Retail

Residential/Commercial DG Customer
Stand Alone Ma SMART <60 kW
With No ESS System

This diagram is representative of a standard design. Please contact Eversource for approval, if a different configuration is needed.

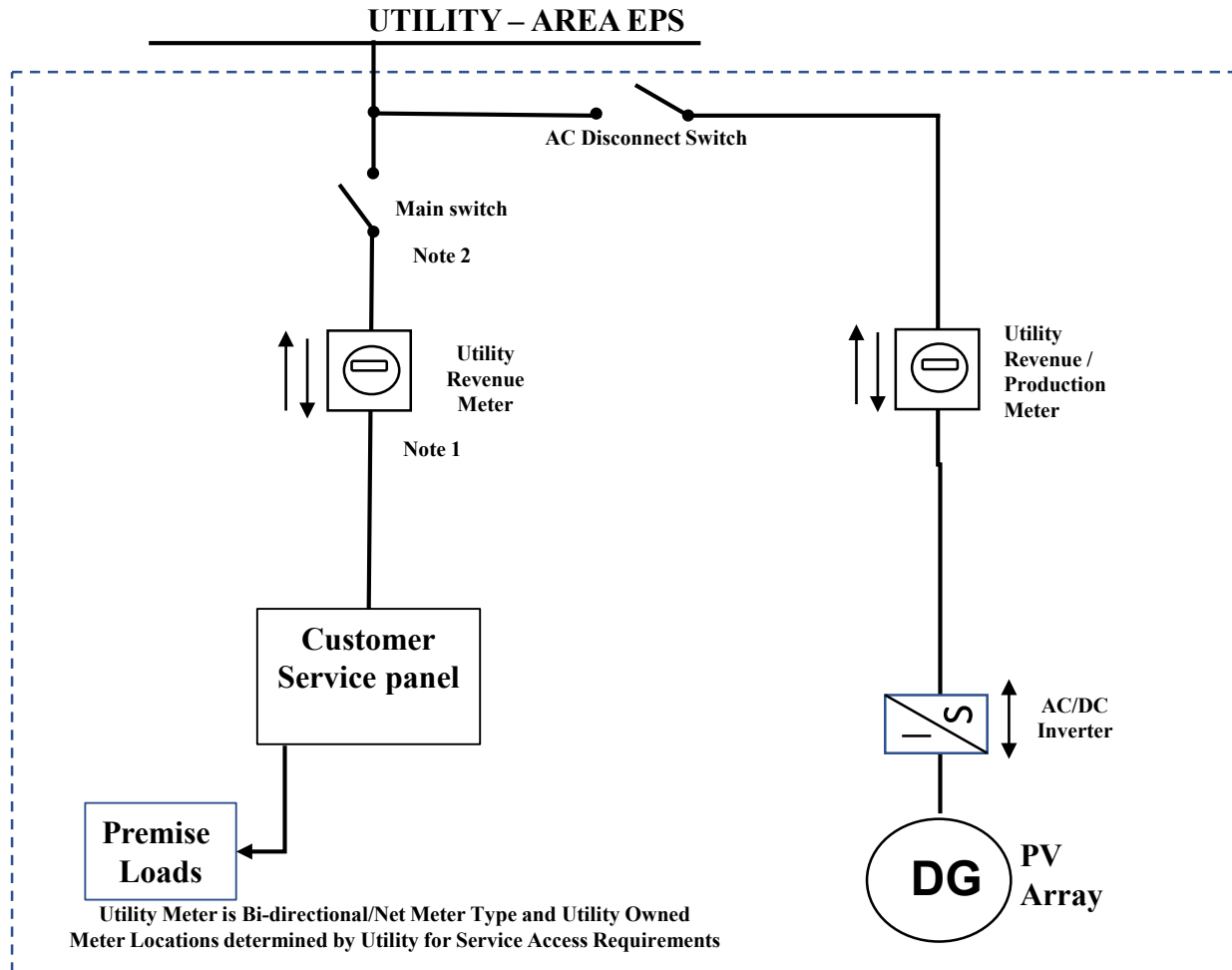

Note 1

- * Utility Meter will be Bidirectional/Net KWH only meter to be used for Utility Revenue and REC determination purposes.
- * Utility meter must be accessible to Utility personnel.

Note 2

- * Following utility I & R book
- * All 277v/480 or instrument rated services required to be cold sequenced as shown in diagram.
- * The Emergency shut off switch shall be within the vicinity of the utility meter and accessible to Utility personnel.

4b. Stand Alone <60kW

Retail Residential/Commercial DG Customer
 Stand Alone Ma SMART <60 kW
 With AC coupled ESS System

This diagram is representative of a standard design. Please contact Eversource for approval, if a different configuration is needed.

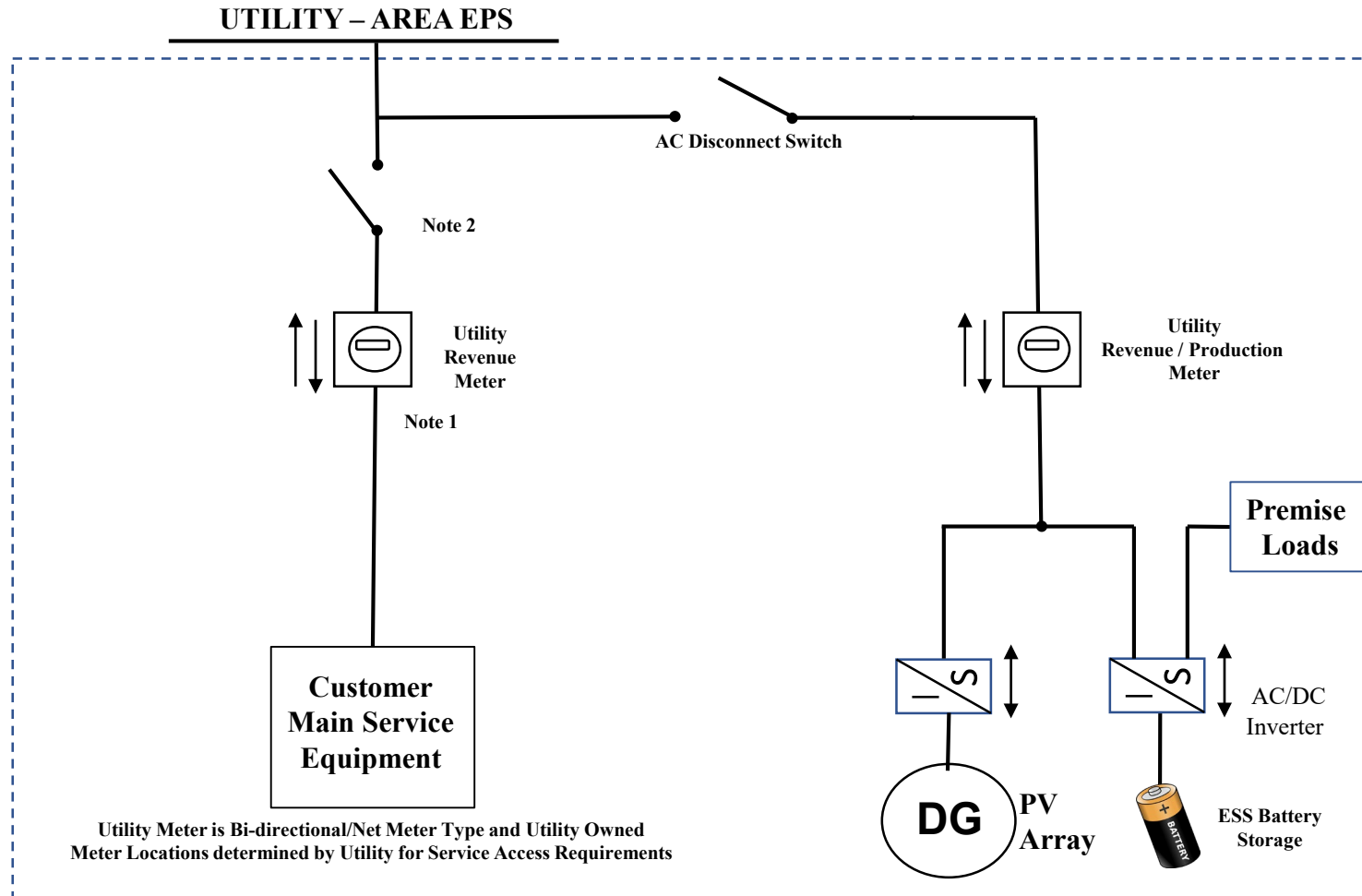

Note 1

- * Utility Meter will be Bidirectional/Net KWH only meter to be used for Utility Revenue and REC determination purposes.
- * Utility meter must be accessible to Utility personnel.

Note 2

- * Following utility I & R book
- * All 277v/480 or instrument rated services required be c old sequenced as shown in diagram.
- * The Emergency shut off switch shall be within vicinity of the utility meter and accessible to Utility personnel.

4c. Stand Alone <60kW

Retail Residential/Commercial DG Customer
 Stand Alone Ma SMART <60 kW
 With DC coupled ESS System

This diagram is representative of a standard design. Please contact Eversource for approval, if a different configuration is needed.

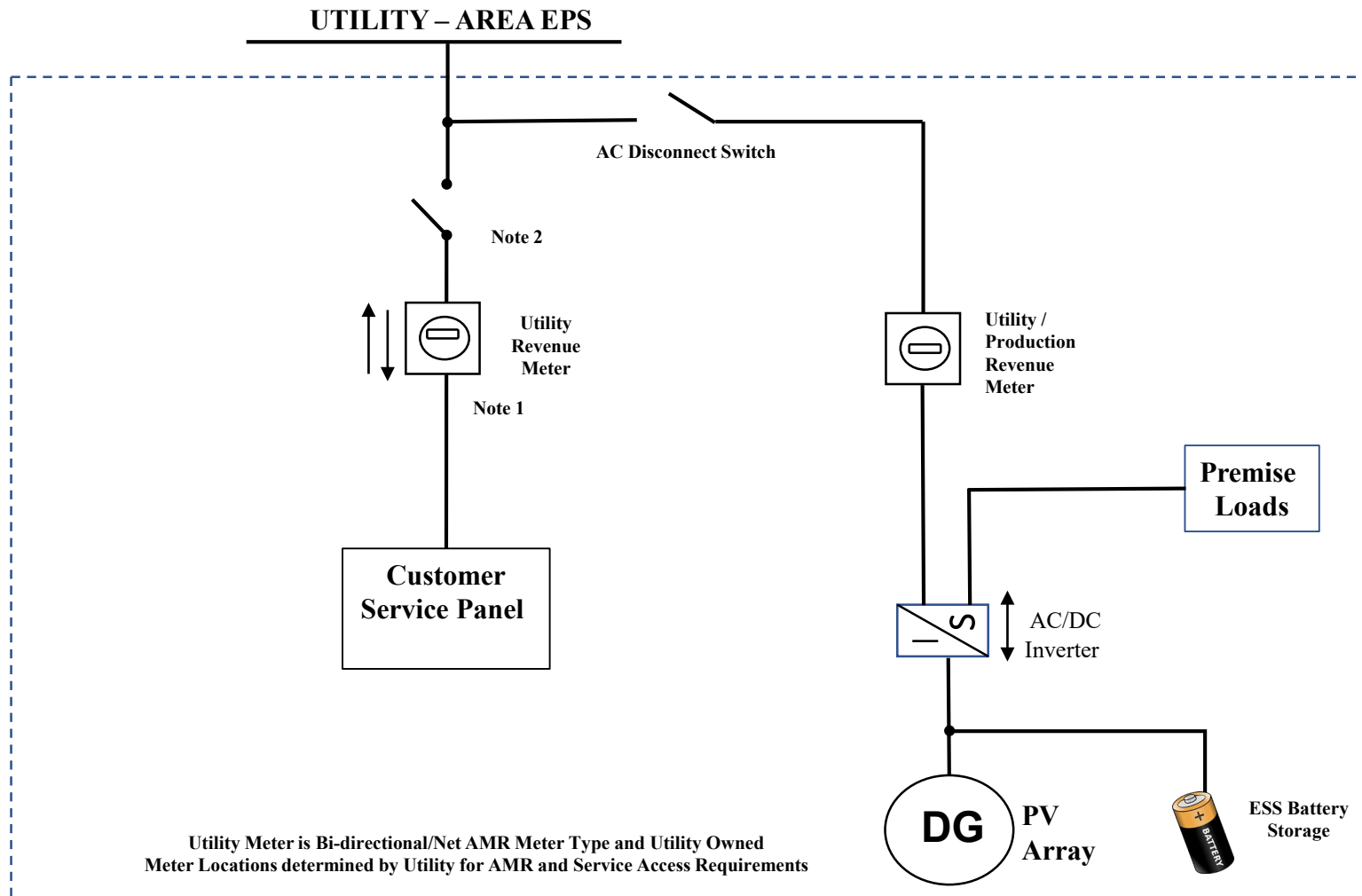

Note 1

- * Utility Meter will be Bidirectional/Net KWH only meter to be used for Utility Revenue and REC determination purposes.
- * Utility meter must be accessible.

Note 2

- * Following utility I & R book
- * All 277v/480 or instrument rated services required be cold sequenced as shown in diagram.
- * The Emergency shut off switch shall be within vicinity of the utility meter and accessible to Utility personnel.

Utility Meter is Bi-directional/Net AMR Meter Type and Utility Owned Meter Locations determined by Utility for AMR and Service Access Requirements

5a. Stand Alone >60kW to 500kW

AC Connection to Utility EPS 60kW – 500kW
 Stand Alone Ma SMART
 Without ESS System
 Utility Service Connection
 3-Phase 4-Wire System
 Secondary Metering

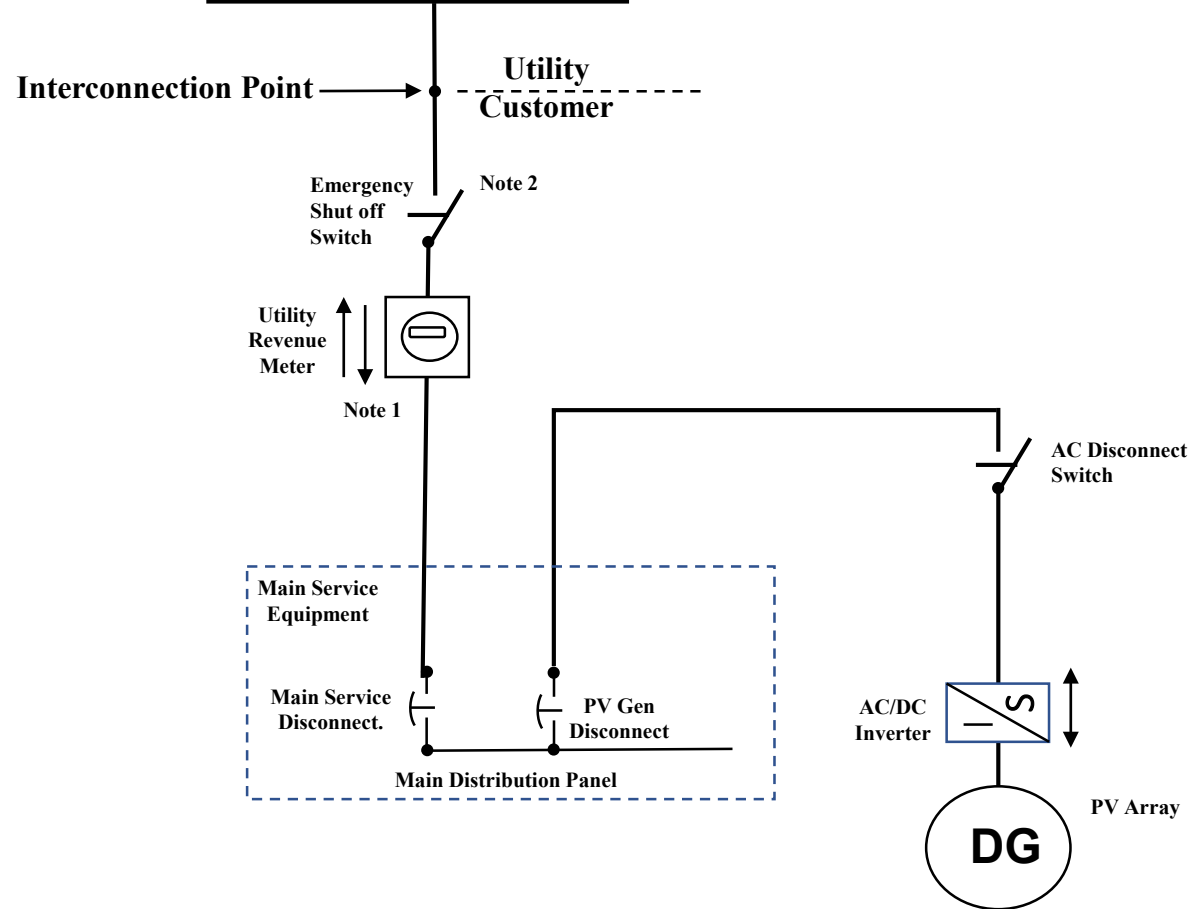

This diagram is representative of a standard design. Please contact Eversource for approval, if a different configuration is needed.

Note 1

- * Utility Meter will be Bidirectional Interval Recording cellular meter to be used for Utility Revenue and REC determination purposes.
- * Secondary metering CTs/VTs may be required.
- * Cellular connection at the meter location is required.
- * Utility Revenue Meter must be accessible.

Note 2

- * All 277v/480 services must be cold sequenced.
- * The Emergency shut off switch shall be within 10 feet of the utility meter and accessible to Utility personnel.

5b. Stand Alone >60kW to 500kW

AC Connection to Utility EPS 60kW – 500kW
 Stand Alone Ma SMART
 With AC ESS System
 Utility Service Connection
 3-Phase 4-Wire System
 Secondary Metering

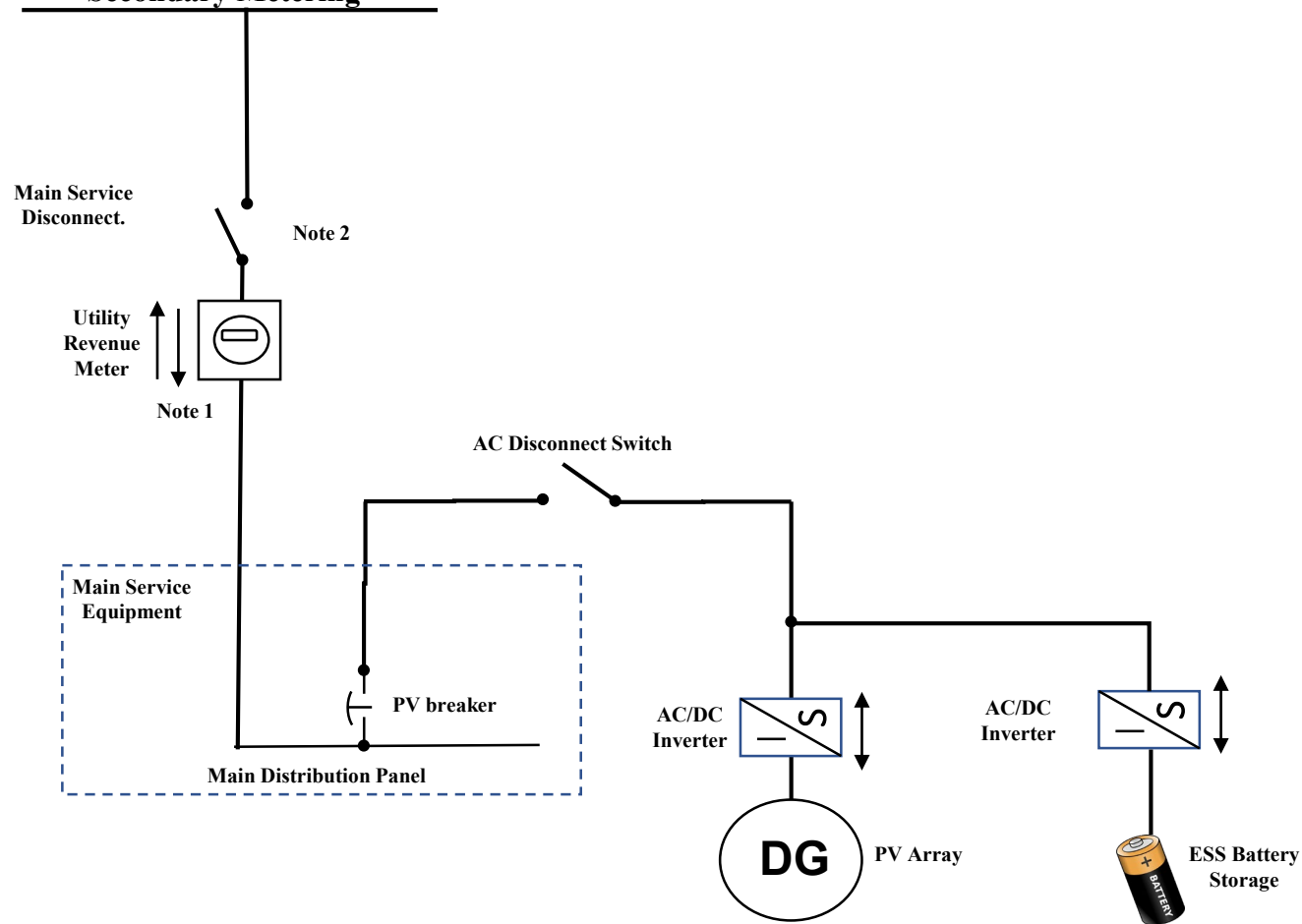

This diagram is representative of a standard design. Please contact Eversource for approval, if a different configuration is needed.

Note 1

- * Utility Revenue Meter installed will be Bi-directional Interval Recording Cellular Meter
- * Secondary metering CTs/VTs may be required.
- * Cellular connection at the meter location is required.
- * Utility Revenue Meter must be accessible.

Note 2

- * All 277v/480 services must be cold sequenced.
- * The Emergency shut off switch shall be within vicinity of the utility meter and accessible to Utility personnel.

5c. Stand Alone >60kW to 500kW

AC Connection to Utility EPS 60kW – 500kW
 Stand Alone Ma SMART
 With DC ESS System
 Utility Service Connection
 3-Phase 4-Wire System
 Secondary Metering

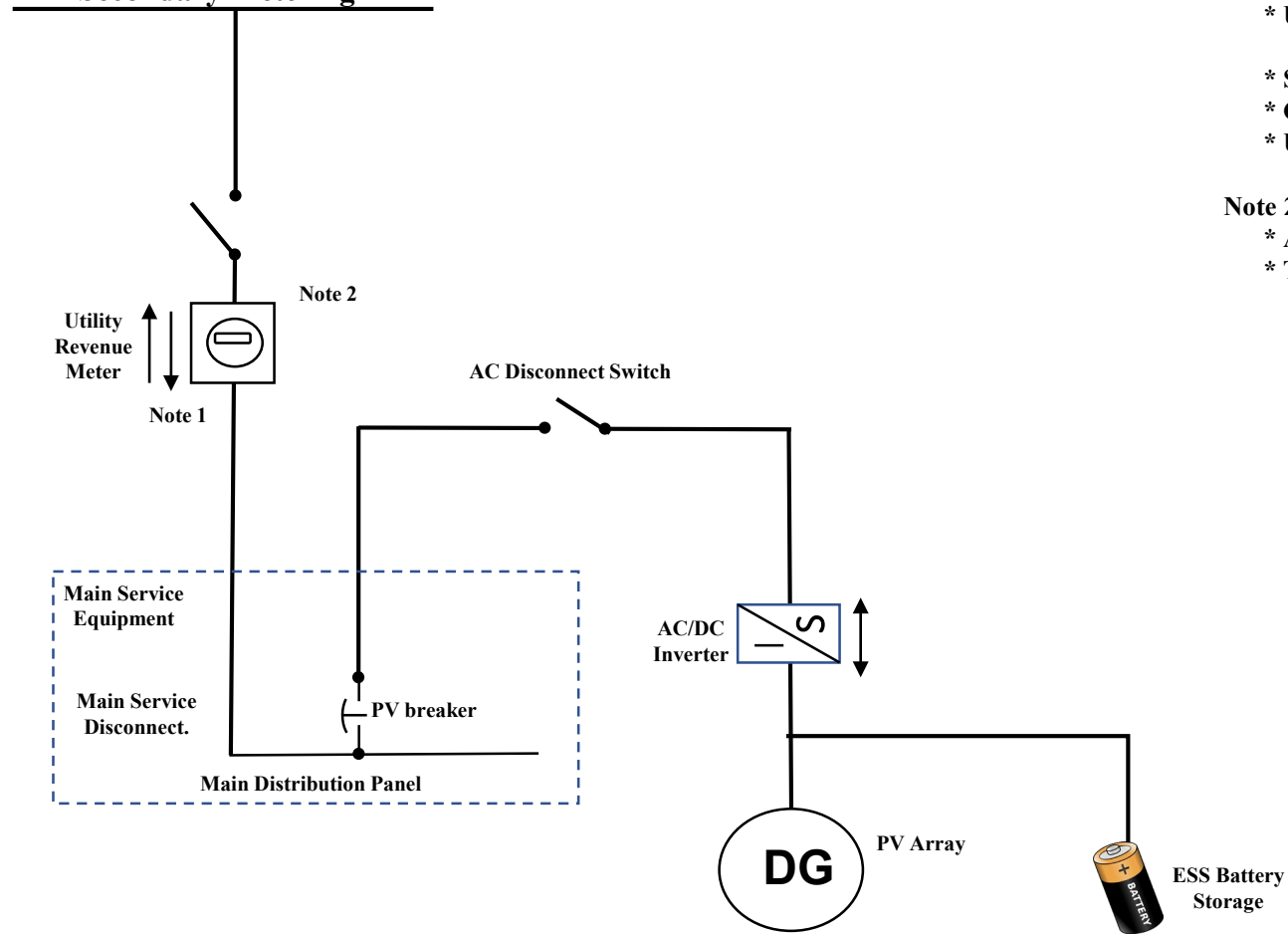

This diagram is representative of a standard design. Please contact Eversource for approval, if a different configuration is needed.

- Note 1**
- * Utility Revenue Meter installed will be Bi-directional Interval Recording Cellular Meter
 - * Secondary metering CTs/VTs may be required.
 - * Cellular connection at the meter location is required.
 - * Utility Revenue Meter must be accessible.
- Note 2**
- * All 277v/480 services must be cold sequenced.
 - * The Emergency shut off switch shall be within vicinity of the utility meter and accessible to Utility personnel.

6a. Stand Alone >500kW

AC Connection to Utility EPS 500kW and Greater
 Stand Alone Ma SMART
 With No ESS System
 Utility Service Connection
 3-Phase 4-Wire System
 Primary Metering

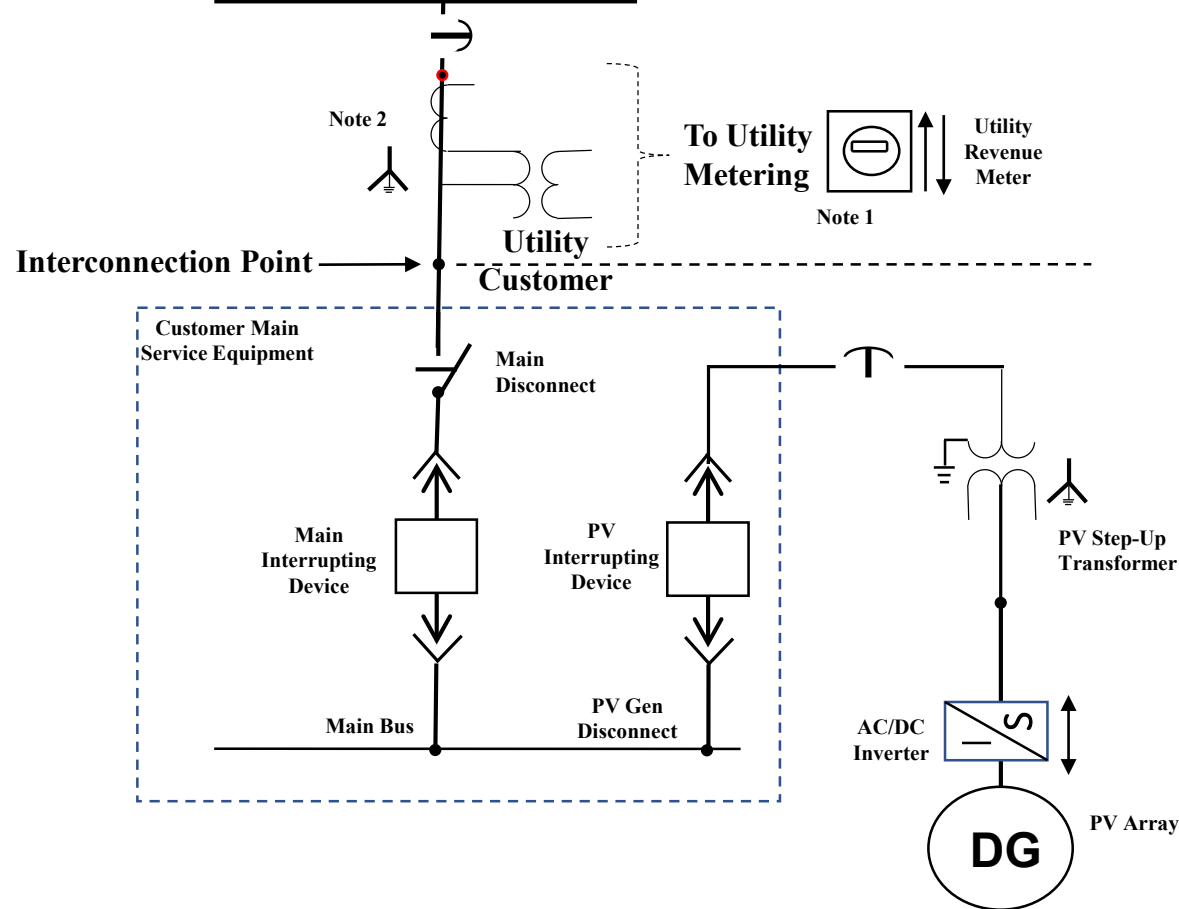

This diagram is representative of a standard design. Please contact Eversource for approval, if a different configuration is needed.

- Note 1
- * Utility Revenue Meter installed will be Bi-directional Interval Recording cellular meter.
 - * Cellular connection at the meter location is required.
 - * Utility Revenue Meter must be accessible.
 - * Follow I&R metering requirements for Cold/Hot sequence metering
- Note 2
- * Polarity Mark of metering transformers is to be toward the Utility Feed

6b. Stand Alone > 500kW

This diagram is representative of a standard design. Please contact Eversource for approval, if a different configuration is needed.

AC Connection to Utility EPS 500kW and Greater
 Stand Alone MA SMART
 With AC ESS System
 Utility Service Connection
 3-Phase 4-Wire System
 Primary Metering

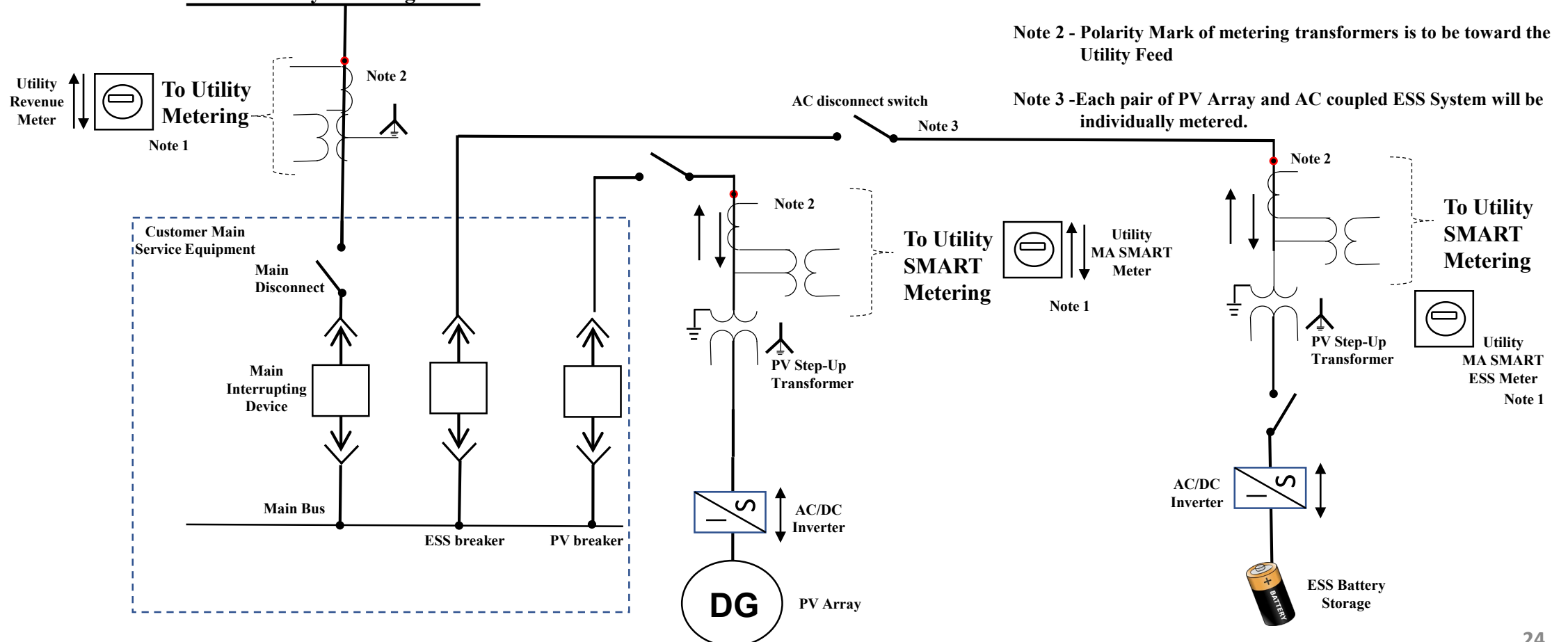

- Note 1
- * Utility Revenue, SMART and ESS Meters will be Bi-directional Interval Recording Cellular meter. Cellular connection at the meter location is required. Utility Revenue Meter must be accessible.
 - * Follow I&R metering requirements for Cold/Hot sequence metering.

Note 2 - Polarity Mark of metering transformers is to be toward the Utility Feed

Note 3 -Each pair of PV Array and AC coupled ESS System will be individually metered.

6c. Stand Alone > 500kW

AC Connection to Utility EPS 500kW and Greater
Stand Alone Ma SMART
With DC ESS System
Utility Service Connection
3-Phase 4-Wire System
Primary Metering

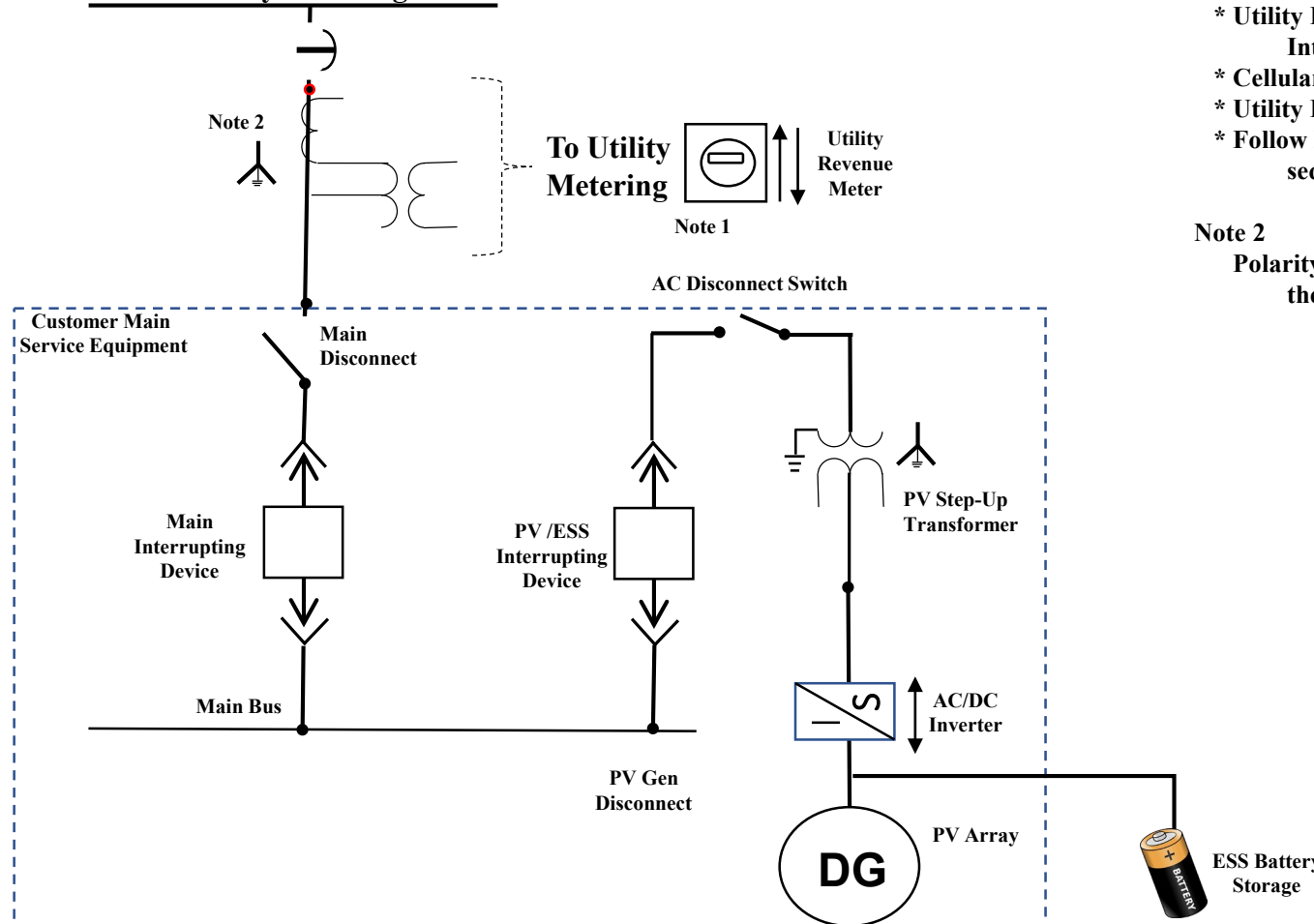

This diagram is representative of a standard design. Please contact Eversource for approval, if a different configuration is needed.

Note 1

- * Utility Revenue Meter installed will be Bi-directional Interval Recording Cellular meter.
- * Cellular connection at the meter location is required.
- * Utility Revenue Meter must be accessible.
- * Follow I&R metering requirements for Cold/Hot sequence metering

Note 2

Polarity Mark of metering transformers is to be toward the Utility Feed